



MASTER
CONICAL ENGINEERING

FRESH ON DEMAND

F10 MASTER CONIC OD

F10 CONIC OD

F8 OD

index

1. SAFETY MEASURES	1
2. DESCRIPTION	2
3. INSTRUCTIONS	3
4. IDENTIFICATION	3
5. TECHNICAL CHARACTERISTICS	4
6. EXTERNAL COMPONENTS	6
7. INSTALLATION	7
8. REGULATION	9
9. OPERATION	12
10. CONFIGURATION	16
11. CLEANING	20
12. MAINTENANCE	21
13. EC CONFORMITY	23



NOTE: The manufacturer will not be held responsible for any damages resulting from improper use of the equipment, or for not following the safety measures as outlined below.

Safety measures incorporated into our grinders:

- **Special screw to maintain the hopper fixed in place.**
- **Access restrictor in the grind group.**

Owners: Please pay careful attention with the following instructions:

- **The grinder should be used exclusively for the function for which it was designed: grinding whole bean coffee.**
- **Do not use this grinder to grind other types of food products such as dry fruit, sugar or spices.**
- **The grinder should not be used by children or individuals with physical, or mental limitations that could result in risk of injury or misuse.**
- **Any other use of the machine will be considered improper and dangerous.**
- **Do not put liquids in contact with internal or external parts of this grinder while ON or OFF, with the exception of parts expressly outlined in the “CLEANING” section of this manual. If liquids do come in contact with the grinder, immediately disconnect electrical connection and carefully clean the affected areas. If it is necessary to access the interior parts of the grinder, contact your local service professional.**
- **In case of any damage to parts or components, we recommend contacting your local service professional to help with repair or replacement of such parts, thereby guaranteeing the maintenance of the security standards of the grinder.**
- **Only an authorized distributor should replace the main power cable of the grinder.**

SOUND DECIBEL LEVEL

The level of sound emitted in different models is:

Sound decibel level	With coffee
F10 MASTER CONIC OD	67,8 dB
F10 CONIC OD	67,8 dB
F8 OD OD	72,2 dB

2. DESCRIPTION

Your new grinder has been designed using the most sophisticated technologies in existence. The result is a product of high quality that offers the assurance of the best results possible. Our products are manufactured by hand, one by one, following the strictest quality requirements. In the manufacturing process, we use only the highest quality materials (aluminum, stainless steel, etc.) especially designated for being in contact with food stuff.

For the optimum functionality of the grinder models described in this user manual, the maximum work cycles are as follows:

Model	Working cycle	
	Function	Stop
F10 MASTER CONIC OD		
F10 CONIC OD	8 sec.	20 sec.
F8 OD		

3. INSTRUCTIONS

3.1. This manual is designed to provide the necessary information to correctly install, use and maintain the grinder, as well as to highlight precautions for users to keep in mind. To ensure the best operation of the coffee grinder, please follow the instructions as outlined in this manual. This manual should be saved for the life of the grinder, and should always be at the disposal of the operator.

3.2. This manual contains special terminology such as:

- Words in **BOLD** indicate important points or terminology.
- Numbers in parentheses after a word, indicate the location of this item in a parts diagram.

Example: (1) - 1 Hopper lid

- Icons:



4. IDENTIFICATION

In the grinder information plaque is the following manufacturing/product information.



NOTE: The manufacturer reserves the right to change components/configurations of any model, according to the different geographic market demands.

		
MODEL	SERIAL NUMBER	
ELECTRICAL DATA	DATE OF MANUFACTURE	ORDER
OPTIONS	OBSER.	
<small>COMPAK Coffee Grinders S.A. Pol. Ind. Can Barri, Moll Barri, parcel·la B, 08415 Bigues i Riells Barcelona, Spain</small>		

5. TECHNICAL CHARACTERISTICS

5.1. Usage

The coffee grinders are intended for use on commercial premises and facilities where ground coffee is required, or in small stores that sell coffee. The grinder must only be used to grind coffee beans. Any use other than this will be considered improper and dangerous.



NOTE: The manufacturer will not be held responsible for any damages resulting from improper use of the equipment, or for not following the safety measures as outlined below.

5.2. Technical data

Model		100 V 50 Hz	100 V 60 Hz	110 V 60 Hz	220 V 60 Hz	230 V 50 Hz	240 V 50 Hz	400 V ^ψ 50Hz	208 V 60 Hz	
F10 MASTER CONIC OD	Electrical power	850	1,000	935	930	950	975	780	840	(W)
	Spin speed	326	378	325	388	340	345	350	390	rpm
F10 CONIC OD	Electrical power	890	960	810	810	800	850	780	840	(W)
	Spin speed	335	388	400	375	325	331	350	390	rpm
F8 OD	Electrical power	750	810	860	735	730	840			(W)
	Spin speed	1,250	1,540	1,600	1,600	1,325	1,330			rpm

	Model						
	F10 MASTER CONIC OD		F10 CONIC OD		F8 OD		
Ø Burrs	2.65 Conical 68		2.65 Conical 68		3.3 83		in mm
Production 50Hz*	37 17		33 15		33 15		lb/h Kg/h
Production 60Hz*	44 20		38.5 17,5		38.5 17,5		lb/h Kg/h
Dose time 50Hz (7 gr)*	1.6		1.9		1.6		Seconds
Dose time 60Hz (7 gr)*	1.4		1.7		1.4		Seconds
Hopper capacity	4.18 1,900		4.18 1,900		4.18 1,900		lb Kg
Mini-hopper capacity (optional)	1.21 550		1.21 550		1.21 550		lb Kg
Net weight	45.3 20,50		37.25 16,93		28.60 13,00		lb Kg
Height	27.95	710	26	660	26	660	
Width	8.46	215	8.46	215	8.46	215	
Depth	15.74	400	17.74	400	17.74	400	
	in	mm	in	mm	in	mm	

* Production is based on a medium-roasted coffee and an Espresso grind.

6. EXTERNAL COMPONENTS



7.1. General warnings

 The person installing the grinder should carefully read this instruction manual before installation. The installation of this machine should be completed by qualified and authorized personnel, and all norms of safety and sanitation should be followed.

7.2. Important warnings

 The operator of the grinder should be a responsible adult, and a never a minor or person incapable of safely using such equipment. **When using the grinder, the following precautions should be followed:**

- No bare feet.
- No wet hands or feet.
- Do not submerge in water.
- Do not expose the grinder to sun or other atmospheric conditions.
- Do not place any type of object in the coffee entrance or exit while the grinder is running. (It should be kept in mind that the cutting burrs continue turning for a couple revolutions after the grinder is powered off).
- To disconnect the grinder, use the main power switch and never the power cable, to avoid a possible short circuit.

7.3. Where to use



The grinder should be installed on a flat, stable surface. The minimum dimensions of the work space should be as follows:

	Model		
	F10 MASTER CONIC OD	F10 FRESH, F8 OD	
Height	28.74	26	in mm
	730	670	
Width	9.05	9.05	in mm
	230	230	
Depth	16.75	16.75	in mm
	420	420	

7.4. Grinder installation

Before grinder installation, the following should be considered:

- The grinder information plaque data coincides with the electrical system on site.
- The electrical outlet coincides with the grinder plug.
- The electric power at the location of installation should meet the minimum required to properly run the grinder.
- The installation site should have the proper electrical overload protections.
- The grinder should be properly grounded as specified by local code.



NOTE: The grinder should be used in environments with minimum temperature of 77-86F and should not be installed in places (such as industrial kitchens) where cleaning is done with direct water spray cleaning.

8.1. Adjusting the lower portafilter support

In order to ensure the proper distribution of ground coffee in the portafilter, while supporting the portafilter in a hands-free position during dosing, it is possible to adjust the height of the lower portafilter support (9).

1. Loosen the two adjustment screws (10) found on each side of the upper portafilter fork (16), by using the *Allen Key* included with your grinder.
2. Adjust the support to the desired height using the portafilter as the point of reference.
3. Tighten the screw (10) found on each side of the upper portafilter fork (16), with the *Allen Key* provided (*Fig. 1*).



NOTE: If the adjustment is extreme (too high or too low), difficulties in operating the dosis button might occur.

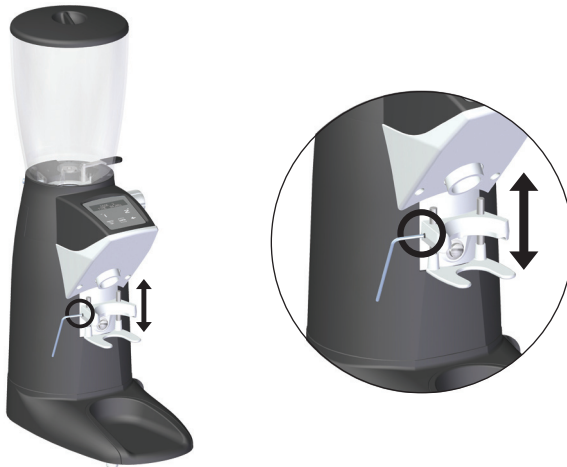

Fig. 1

8.2. Adjust the lower portafilter support in models with Dynamometric press system DYN

1. Remove screw caps (*Fig. 2*) using a flat headed screw driver.
2. Adjust the mobile fork as described in section 8.1.
3. Replace and tighten the screw caps (*Fig. 2*).

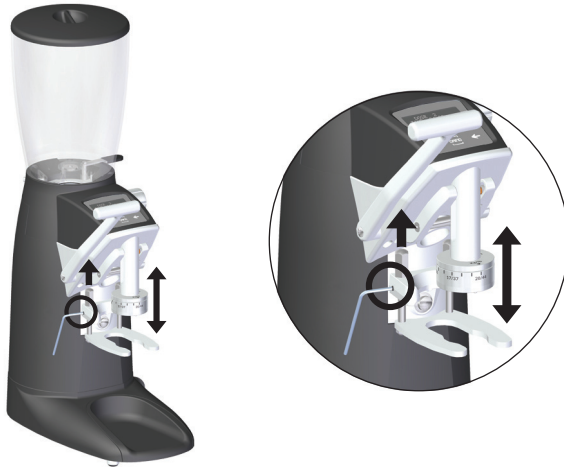

Fig. 2

8.3. Grind point adjustment

Place portafilter in upper portafilter holder (16) and push the refill button (8) until ground coffee begins to dispense from exit chute.

To adjust the grind point, simply turn the grind adjustment knob. A clockwise adjustment will render a finer grind and a counter clockwise adjustment will render a more coarse grind.

CAUTION: Changing grind settings must be done when the grinder is on and burrs are in motion. Not doing this supposes that the burrs will gunk up and cleaning will be required.



NOTE: If the output is very slow, it could mean that the coffee is being ground too fine. If the output is very fast, it could mean that the coffee is being ground too coarse. A perfect espresso grind is found when the grind point gives an infusion of 25 ml of coffee in 25 seconds using 7 grams of ground coffee.

When turning the grind adjustment knob it should be noted that a grind point reference scale of 1 to 800 will appear on the main display (14). This scale should be used as a reference in setting the desired grind point.

TIP: Our grinders are delivered to an estimated calibration of Espresso grind, been able to adjust this functionality depending on the type of coffee, type of roast and dosage used.

F8 OD	80-120
F10 CONIC OD, F10 MASTER CONIC OD	350-450

8.4. Coffee grinder preparation

The grinder should rest on a flat, hard surface in close proximity to the coffee machine. To guarantee proper operation, the minimum work space should measure at least 310 mm wide by 400 mm deep by 800 mm high.

Unpack the grinder carefully and place it in the assigned work space. Before placing the bean hopper on the grinder, loosen the security screw found on the upper collar of the grinder (5). Place the bean hopper (2) on the upper part of the grinder so that the bean trap lever (4) is positioned on the right side of the grinder in the **CLOSED** position (Fig. 1). Once the bean hopper is placed on the grinder, rotate it clockwise until it is firmly in place and can rotate no further. If desired, replace the hopper security screw (5) to ensure the hopper cannot be removed manually.

Place beans in the hopper and replace hopper lid (1). Finally, the bean trap lever (4) must be in an open position, allowing the beans to fall into the grinding chamber.

Before plugging in the grinder, confirm that the electrical configuration found on the description plaque on the grinder matches the power on site. Once confirmed, plug in the grinder and press the 3 position switch (13) to position *I* (**AUTOMATIC MODE**).



Fig. 3

9. OPERATION

9.1. General switch

The general switch (13) has 3 positions of use, **AUTOMATIC**- **OFF** - **MANUAL**.

AUTOMATIC: Electrical functions

OFF: Off

MANUAL: Manual mode. Security system that allows using the grinder in case of supply plate or keypad failure. By activating **MANUAL** mode, the grinder starts grinding until returning to de mode **OFF**.

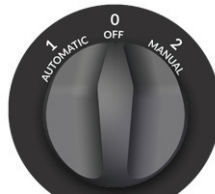

9.2. Utilization

Through the program menu (Fig. 4), it is possible to select two distinct functional modes: **AUTOMATIC**, **PRESLECT** and **MANUAL**.



Fig. 4

9.3. Automatic mode

In this mode, user should press/release the appropriate numeric LCD icon (15) once for a single dosis, twice for a double dosis and three times for a triple dosis. The display screen (14) will indicate an icon representing either a single, double or triple* dose, along with the programmed time of the dose counting down from total dose time to zero.

Also, once the dose cycle has been activated, the dosis button (11) can be pressed/released, to suspend the cycle. If the dose pulse button is pressed/released again, within 8 seconds, the cycle will continue from the point at which it was suspended. If more than 8 seconds pass, the dose cycle will start a new, complete dose cycle.

Pausing the grind cycle can be done by selecting **MENU / SET UP SETTINGS / SET UP GRIND PAUSE**.

* (only for models with possibility to offer three doses).

9.4. Preselect mode

In this mode, a single, double or triple dose setting is selected using the configuration buttons (15). The preselection of a single, double or triple* dose will remain active until changed by selecting another dose option. The preselection will be illustrated on the display screen with the corresponding icon (14).

The preselected dose is activated with a single press/tap of the appropriate numeric LCD icon (15). The display screen (14) will indicate an icon representing either a single, double or triple dose, along with the programmed time of the dose counting down from total dose time to zero.

Also, once the dose cycle has been activated, the dosis button (11) can be pressed/released, to suspend the cycle. If the dose pulse button is pressed/released again, within 8 seconds, the cycle will continue from the point at which it was suspended. If more than 8 seconds pass, the dose cycle will start a new, complete dose cycle.

Grind pause can be activated or deactivated by pressing the lower pulse button (11). First, set up by following these steps: **MENU / SET UP SETTINGS / SET UP GRIND PAUSE**.

* (only for models with possibility to offer three doses).

9.5. Instant Mode

In this mode of operation when making the selection of one, two or three* doses of coffee by pressing the appropriate numeric LCD icon (15) screen starts grinding the selected dosis without the need to actuate the lower dose button (11).

The time set for that dose will decrease to zero, at which point the dose ends.

Once the cycle starts grinding using the lower dose button (11) and is pressed again, the grinding cycle will stop. If within 8 seconds it is pressed again, it will complete the remaining time of the original dose time setting. After 8 seconds of inactivity the grinder will return to standby mode.

To pause by pressing the lower activation button (11), you can enable or disable, accessing **MENU / SET UP SETTINGS / SET UP GRIND PAUSE**.

In this mode, pause grinding may also be performed by pressing the active icon on the LCD display (15) this pause cannot be enabled or disabled via the **MENU**.

* (only for models with possibility to offer three doses).

9.6. Refill button

If you press and hold down on the refill button (8), you can manually refill the porta with the desired amount of ground coffee.

9.7. Press

9.7.1. Fixed press

Position the portafilter below the tamper and push up to tamp the ground coffee (Fig. 5).

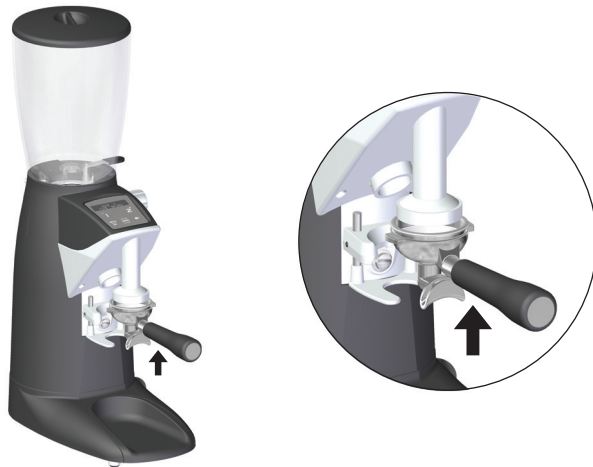

Fig. 5

9.7.2. Dynamometric press DYN (optional)

Position the portafilter in the fork, regulate the tamp with the desired strength between 11 Kg minimum until 20 Kg maximum, and push down the lever in the side to press the coffee in the portafilter. The dynamometric press strength is right when you can listen “click” when the tamper presses the coffee in the portafilter.



Fig. 6

10. CONFIGURATION

There are two distinct configuration differences which are as follows:

- **Configuration of time for a single, double or triple* dose.** Procedure to follow by the operator that can be realized at any time without password protection.
- **Configuration of the grinder's main menu.** Procedure to follow when using the advanced features found in the main menu that can be password protected.

* (only for models with possibility to offer three doses).

10.1. Configuration of the grinding time

The grind times can be configured for the **AUTOMATIC**, **PRESELECT** and **INSTANT** modes. When modifying in one of three modes are updated for all modes simultaneously.

To modify the time of one dose, press the time of the respective dose numerical icon (**1**, **2⁺** or **3⁺**) on the touch screen **twice** (double tap), followed immediately (2 seconds or less) by pressing the **MENU** button.

You can also change the time of a dose accessing **MENU / SET UP SETTINGS / SET UP TIME / TIME DOSE 1, 2, 3***.

*(only for models with possibility to offer three doses).

Automatically the icon of the desired dose icon and the $\frac{\text{MENU}}{\text{OK}}$ icon will change to active color and the four time numbers will then begin to flash.

There are two ways to modify the time:

- Press the icons $\mathbf{2}^+$ or $\mathbf{3}^+$ on the LCD screen and the time will increase, and press the icon $\mathbf{1}$ to decrease the time.
- Also, the time can be changed by using the lower dose button (11) or the $\frac{\text{GRIND}}{\text{OK}}$ icon (8) found on the LCD screen (15). If any of these options are pressed, the grinder will begin to run and the time, starting at zero, will increase until the chosen button is released.

10.2. Configuration of the grinder's main menu

To enter the configuration menú, press the $\frac{\text{MENU}}{\text{OK}}$ icon. Once in the menu, use the buttons ($\mathbf{1}$, $\mathbf{2}^+$ or $\mathbf{3}^+$) to toggle through the menu options, and confirm/choose the desired option with the $\frac{\text{MENU}}{\text{OK}}$ button. Press the \leftarrow icon to return to the previous option.

To exit the menú, press the arrow button until the main menu screen is reached, or simply press nothing for 8 seconds and the menu will reset to the beginning.

Through the configuration menu, it is possible to modify the following grinder features:

SET UP LANGUAGE	ENGLISH	ENGLISH ACTIVE			
	FRANÇAIS	FRANÇAIS ACTIVE			
	DEUTSCHE	DEUTSCHE AKTIV			
	ITALIANO	ITALIANO ATTIVO			
	PORTUGUESE	PORTUGUESE ATIVA			
	ESPAÑOL	ESPAÑOL ACTIVO			
VIEW USAGE DATA	NUMBER OF SINGLE SERVINGS	COFFEE COUNTER ABSOLUTE	COFFEE COUNTER DOSE 1	01/01/2015 0000000	
			COFFEE COUNTER DOSE 2	01/01/2015 0000000	
			COFFEE COUNTER DOSE 3	01/01/2015 0000000	
	COFFEE COUNTER RELATIVE	COFFEE COUNTER DOSE 1	01/01/2015 0000000		
		COFFEE COUNTER DOSE 2	01/01/2015 0000000		
		COFFEE COUNTER DOSE 3	01/01/2015 0000000		
BURR WARE DATA	ALARM 00000 Kg GROUND 000000 Kg				
SET UP SETTINGS	OPERATING MODE	OPERATING PRESELECT	PRESELECT MODE ON		
		OPERATING INSTANT	INSTANT MODE ON		
		OPERATING AUTOMATIC	AUTOMATIC MODE ON		
	SET UP PASSWORD <i>(Limits access to menu)</i>	ENABLE PASSWORD	PASSWORD MODE ON		
		DISABLE PASSWORD	PASSWORD MODE OFF		
		SET UP PASSWORD	PASSWORD CURRENT 0000	PASSWORD NEW 0000	PASSWORD MODIFIED
	SET UP DATE/TIME	SET UP TIME	CURRENT TIME 00:00:00	TIME MODIFIED	
		SET UP DATE FORMAT	DATE FORMAT DD/MM/YY	DATE FORMAT MODIFIED	
			DATE FORMAT MM/DD/YY	DATE FORMAT MODIFIED	
		SET UP DATE	CURRENT DATE 00/00/00	DATE MODIFIED	
	SET UP SOUND	ENABLE SOUND	SOUND MODE ON		
		DISABLE SOUND	SOUND MODE OFF		
	ALARM BURR CHANGE** <i>(Activates display at beginning/ending of service)</i>	ENABLE ALARM	ALARM MODE ON		
		DISABLE ALARM	ALARM MODE OFF		
		RESET ALARM	ALARM RESET		
		SET UP ALARM	WEIGHT DOSE 2 14.00 gr (**)	Kg. BURR CHANGE 00500 Kg	ALARM MODIFIED
	RESET RELATIVE COFFEE COUNTER	RELATIVE COFFEE RESET			
	GRIND PAUSE SET UP	ENABLE GRIND PAUSE	GRIND PAUSE ON		
		DISABLE GRIND PAUSE	GRIND PAUSE OFF		
	SETTINGS GRIND SETTINGS	GRIND SETTINGS RESETS			
	TIME SET UP	TIME DOSE 1	DOSE 1 TIME 02.00s		
TIME DOSE 2		DOSE 2 TIME 04.00s			
TIME DOSE 3 (*)		DOSE 3 TIME 06.00s (*)			

11. CLEANING

11.1. General cleaning

To ensure that the grinder functions properly, and produces the highest quality grind possible, the parts that come into contact with coffee should be cleaned periodically.

General Cleaning guidelines as follows:

- Always turn the main power switch to the **OFF** position (13).
- Unplug the machine from the power source.
- Do not submerge the grinder in water or use power washing devices.

11.2. Bean hopper cleaning

In order to properly clean the bean hopper (2), empty out all remaining beans and fragments.

To remove the hopper, close the bean trap (4), and loosen the hopper lock screw (5) and lift the hopper straight up.

Clean the hopper (2) with a moist soft cloth or with a small amount of water and soap to eliminate any oily residue from the beans.

Replace the bean hopper (2) following the same steps as the removal process, but in reverse.

11.3. Cleaning the grind chamber

It is recommended that the grind chamber be cleaned daily with a cleaner as recommended by **Compak**. This process will eliminate smelly residues from the coffee remains, which can negatively affect the quality of the brewed coffee.

The steps to follow are:

In order to properly clean the bean hopper (2), first empty out all remaining beans and fragments.

- Close the bean trap on the hopper (4) and grind out the remaining coffee in the grind chamber.
- Remove any remaining coffee beans from the bean hopper (4).
- Pour the recommended grinder cleaning product into the bean hopper (2) and open the bean trap (4), allowing the cleaning product to pass into the grind chamber.

- Grind the cleaning product at a medium course grind setting until the recommended amount is passed through the system and nothing remains in the grind chamber.
- Clean the hopper (2) and refill with coffee beans.
- Discard the first 2-3 doses of coffee to assure that the residual cleaning product is removed from the grind chamber and set the grind regulator to the desired setting (7).

Following these steps will ensure that the grinder is clean and ready for use.

We do not recommend the taking apart of the grind assembly unless changing burrs, or removing a blockage/obstruction in the grind chamber. Removal of the grind assembly should be performed by a qualified service technician.

11.4. Cleaning the outside of the grinder

To clean the exterior of the grinder, first wipe with a dry soft cloth, and then gently wipe with a damp soapy cloth.

12. MAINTENANCE

12.1. General warning

Before performing any type of maintenance:

- Always turn off the main power switch to the **OFF** position (13).
- If the grinder is jammed, unplug it from the power source and contact an authorized service technician.



Not following these warnings can compromise the safety of the grinder as well as the user.

12.2. General maintenance of the grind chamber

To guarantee the efficiency and correct operation of the grinder, it is essential to follow manufacturer instructions and ensure that all maintenance work is carried out by qualified staff.

Dull burrs will result in a lower quality grind, greater heat generation in the coffee and grinder, increased electrical consumption, and finally it puts additional stress on the grinder motor.



NOTE: Based on extensive experience and a medium-hard coffee blend, we recommend replacing the burrs following the quantities in next table:

	Steel	Red Speed Lucidate
F8 OD	800 Kg	3500 Kg
F10 CONIC OD	1200 Kg	7500 Kg
F10 MASTER CONIC OD	1200 Kg	7500 Kg

12.3. Silicon curtain replacement (F8 model)

The silicon curtain ensures consistency in the dose and reduces static electricity. Located inside the coffee outlet (12), it can be replaced by following the steps below:

1. Remove the grind regulator control knob (7) loosening the fixing bolt with an *Allen key No. 2.5*.
2. Remove the four screws securing the cover using an *Allen key No. 2.5*.
3. Remove the four screws fixing the base of aluminum siding, using an *Allen key No. 2.5*.
4. Remove the coffee outlet (12), by removing the two retaining screws using an *Allen key No. 2.5* At this point, access to the silicon curtain is possible. Replace the silicon curtain with a new silicon curtain of different thicknesses according to the needs of each coffee. Simply remove the screw curtain using a #10 *Torx wrench*.

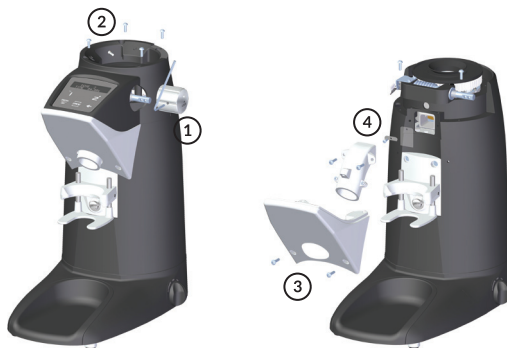

Fig. 7

In accordance with European community directives, quality certificates have been applied. All materials have been adapted and technical reports are available at our offices.

04/108/EC on the approximation of the laws of the Member States relating to electromagnetic compatibility.

06/42/EC amending Directive 89/392/EC on the approximation of the laws of the Member States relating to machinery

REG. 1935/2004 amending Directive 89/109/CE on the approximation of the laws of the Member States relating to material and objects destined to make contact with nutritional products.

03/108/EC amending Directive 2002/96/EC on waste electrical and electronic equipment (WEEE).

06/95/EC of 12/12/2006 on the harmonization of the laws of Member States relating to electrical equipment designed for use within certain voltage limits.

02/96/EC of 27/01/2003 on the approximation of the laws of the Member States on waste electrical and electronic equipment (WEEE).

11/65/EU related to the restriction on the usage of certain dangerous substances with electrical equipment and electronics.



Environment

Do not throw the appliance away with the normal household waste; hand it in at an official recycling collection point. By doing this, you will help to preserve the environment.

The Legal Representative
Jesús Ascaso



Compak Coffee Grinders, s.a.

Moli Barri, Parcela B - Pol. Ind. Can Barri - 08415 Bigues i Riells - Barcelona - Spain
Ph. 34 93 703 13 00 - Fax 34 93 703 13 23 - www.compak.es

